

Lateral

vehicle access excellence



FIAT NEW DOBLO SWB

Launched in 2010, New Doblo SWB is more refined, bigger and better, with a range of modern, fuel efficient engines and innovative comfort & convenience features. Mated to our tried & tested conversion design-engineering, Lateral New Doblo SWB sets the new benchmark in domestic wheelchair accessible vehicles.

Previous model Doblo provided the base vehicle for our first, and subsequently hugely successful, wheelchair accessible car conversion. Hugely practical, Doblo became the mainstay of the small to medium size WAV market, finding favour with Motability users, transport services, and taxi companies -alike.

Eight years and over eight-hundred Doblo conversions later, Lateral proudly present our latest low-floor offering built upon New Doblo SWB. Already in great demand, this vehicle is set to become the most popular choice for family & wheelchair transportation.

Now available in two body sizes (short and long –wheelbase), New Doblo is even more spacious, with a considerable range of specification options available to tailor vehicles to individual requirements.

The 2010 model benefits from numerous technical innovations, most notably including the 'Blue&Me' Bluetooth and USB entertainment and communication interfaces, EcoDrive navigation software, and, for even greater fuel economy, the Fiat 'Start&Stop' on/off ignition system.

Lateral's conversion upon the SWB variant features a generous 800mm –wide by 1400mm –long (nominal) stainless-steel low-floor subframe, which extends from the rear of the vehicle to behind the row1 seats. Optional passenger seats may be located to the nearside and offside of row2, further contributing to the vehicle's versatility. Another high quality, light of action Lateral bi-fold ramp provides easy wheelchair access to the rear.

Lateral specify Q'Straint electroreels, rear retractors, and 3-point belts to provide safe and secure wheelchair occupant restraint.

**LATERAL NEW DOBLO SWB:
THE NEW BENCHMARK VEHICLE, CONVERTED BY THE EXPERTS IN ACCESS**

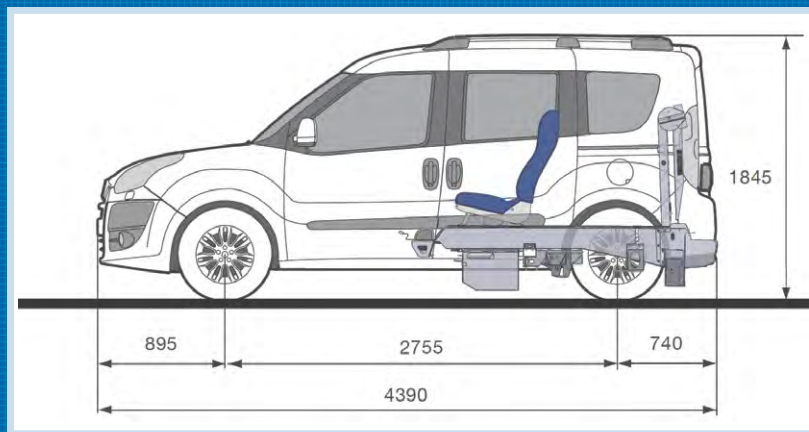

Drawing for illustrative purposes only.

FIAT DOBLO SWB LOW-FLOOR WAV

Ramp type - Bi-fold
 Ramp length - 1550mm
 Ramp width - 780mm
 Ramp entry angle - 12°

Nominal subframe interior length* - 1400mm
 Nominal subframe interior width** - 800mm

Entry height - 1380mm
 Internal height - 1400mm

*from interior face of ramp to cab step-up

**based upon carpeted interior surfaces of subframe

***at occupant position

Lateral

vehicle **access** excellence

tel.

+44 (0)1535 66 22 44

fax.

+44 (0)1535 66 22 64

email.

info@lateraldc.co.uk

web.

lateraldc.co.uk

address.

River Technology Park

Brewery Street

Keighley

West Yorkshire

BD21 4JQ

