

LOW-FLOOR ACCESS KITS

Lateral began revolutionising lowered floor –type WAV conversions when we launched our first kit for ‘Classic’ Doblo in 2003. Whilst the basic principal of ‘low-floor’ conversions is common to many manufacturers, it is the unmatched creativity of our designs, the precision of our engineering, the intelligence of our installation method, and the quality and consistency of our products’ finish, that set our kits apart.

Designed and produced in our state of the art factory, and supported by our unparalleled experience in WAV testing and approval procedures, Lateral Low-Floor kits are the premier choice for converters across the UK and Europe.

Lateral Low-Floor systems are designed using 3-D ‘Solidworks’ CAD software to produce kits that drop perfectly in to each of our chosen base vehicles’ platforms, with carefully chosen fixation positions eliminating any need for welding of conversion parts to base vehicles during installation. Subframes are designed for optimum vehicle seating versatility, and maximum internal width and head clearance.

Our subframes are manufactured from Nirosa stainless steel materials, cut and folded with dimensionally perfect precision, each time, every time, by our **Bystronic™** laser cutting and **Beyeler Xpert™** press –brake machinery. Our highly-skilled technicians assemble subframes using digitally controlled synergic pulse welding equipment for consistent material penetration and assembly strength.

One of our greatest talents is in the design and development of beautifully balanced and effortless to operate access ramps. Dependent upon model, Lateral Low-Floor WAV systems may be supplied with single section or bi-fold honeycomb composite ramps, all with a tangibly superlative finish, trimmed with high-visibility markings and anti-slip walkway materials.

New customers can be confident when specifying Lateral Low-Floor systems, having benefited from the detailed installation training and support that we provide. Alternatively, we also offer in-house conversion of vehicles in our sixteen bay workshop.

The Lateral range of Low-Floor WAV kits continues to grow, catering for new and carefully selected base vehicles, and with relentless pursuit of perfection and innovation in our designs. Recent additions to the Lateral Low-Floor WAV family include Fiat Qubo, Fiat New Doblo (SWB & LWB), and Renault New Kangoo.

With total confidence in our Low-Floor products, we offer a two-year* aftersales warranty.

**first year parts and labour, year 2 parts –only*

LATERAL LOW-FLOOR ACCESS KITS: THE BENCHMARK IN WAV PRODUCTS SINCE 2003

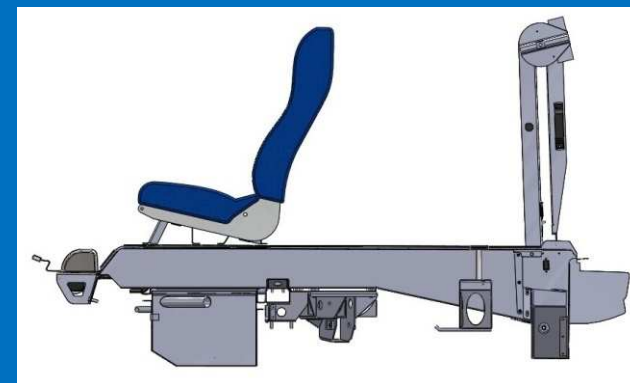
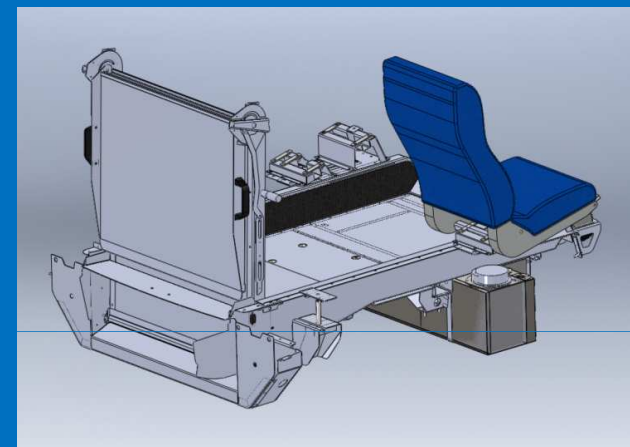

address.
River Technology Park
Brewery Street
Keighley
West Yorkshire
BD21 4JQ